

OLMO

CARACTÉRISTIQUES :

- . Entièrement réalisé en inox AISI 304 (1.4301)
- . Chariot ouvert sur 3 cotés et 3 espaces de stockage pour le linge propre, combiné à deux portes-sacs fixes Osu Duty pour le linge sale/déchets
- . Avec 4 roues pivotantes Ø 125 mm avec butoirs annulaires

OPTIONS :

- . Roues à freins
- . Couvercles

EIGENSCHAFTEN :

- . Gestell aus Edelstahl AISI 304 (1.4301)
- . Offenen Etagenwagen, mit 3 Ablageflächen für saubere Wäsche und kombiniert mit 2 Wäschesammlern Osu Duty fixmontiert für Schmutzwäsche/Abfall
- . 4 Lenkrollen Ø 125 mm mit Abweiserrollen

OPTIONEN :

- . Bremse
- . Deckel



2 100 200



2 100 201

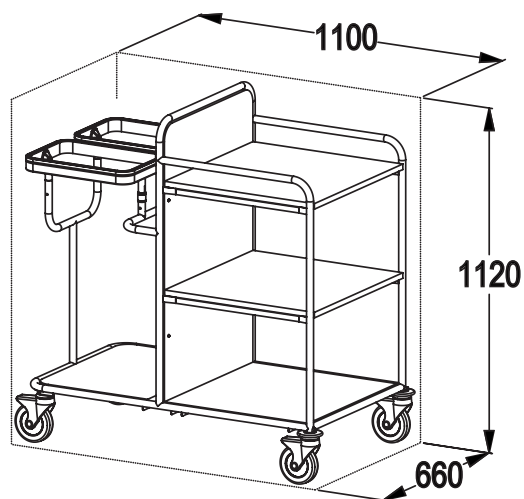
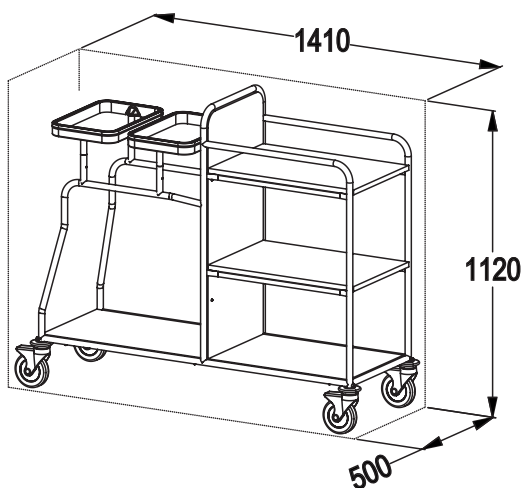

OLMO

INSTRUCTIONS DE MONTAGE DU SAC - ANLEITUNG SACKBEFESTIGUNG



OPTIONS - OPTIONAL

2 100 082

2 100 092



2 100 082. Charnière pour ouverture manuelle du couvercle
 . Scharnier für manuelle Öffnung, ohne Pedal.

2 100 092. Couvercle en plastique ABS bleu
 . Deckel aus Kunststoff ABS Blau



COULEURS DE COUVERCLES / DECKEL FARBEN



Blanc - Weiss

2 100 091



Bleu - Blau

2 100 092



Jaune - Gelb

2 100 093



Vert - Grün

2 100 094



Rouge - Rot

2 100 095



Brun - Braun

2 100 096

www.mercura-industries.ch

OLMO

DIMENSIONS EXT.
 L x l x H mm
 AUSSENMASSE

ROUES
 Ø mm
 ROLLEN

2 100 200

1410 x 500 x 1120 mm

125

2 100 201

1100 x 660 x 1120 mm

125

Dim des anneaux : 350 x 255 mm - Ringmasse : 350 x 255 mm

